HA17555 Series

Precision Timer

HITACHI

ADE-204-064 (Z)
Rev. 0
Dec. 2000

Description

HA17555 Series are ICs designed for accurate time delays or oscillations. It provides both of trigger terminal and reset terminal in order to enable a wide scope of application including Mono Multi Vibrator and Astable Multi Vibrator, and the number of external components is fewer. Further, it's compatible with NE555 of singnetics.

Features

- Mono multi vibrator can be constructed with one resistor and one capacitor.
- Astable multi vibrator can be constructed with two resistors and one capacitor.
- Delay time can be established widely from several μ seconds to several hours.
- Pulse Duty can be controlled.
- The maximum value of both sink current and source current is 200mA.
- Direct connection of output to TTL is possible.
- Temperature/delay time ratio is 50 ppm/ $^{\circ}$ C (typ).
- Output is normally in the on and off states.

Ordering Information

Application	Type No.	Package
Industrial use	HA17555PS	DP-8
	HA17555FP	FP-8D
Commercial use	HA17555	DP-8
	HA17555F	FP-8D

Applications

- Delay Time Generator (Mono Multi Vibrator)
- Pulse Generator (Astable Multi Vibrator)
- Pulse Width Modulator
- Pulse Location Modulator
- Miss Pulse Detector

Pin Arrangement

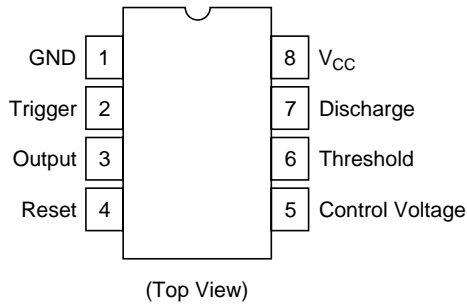

Pin Description

Pin No.	Function
1	Ground pin
2	Trigger pin
3	Output pin
4	Reset pin
5	Control voltage pin
6	Threshold pin
7	Discharge pin
8	V_{cc} pin

Circuit Schematic

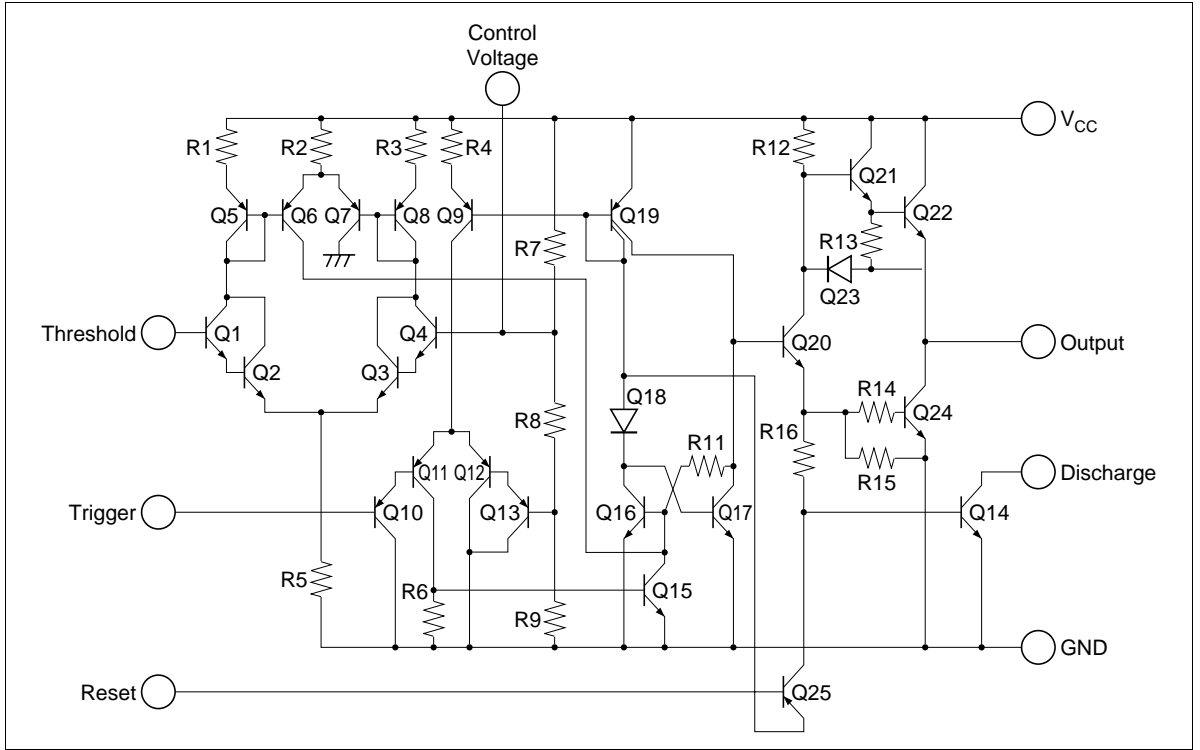

Block Diagram

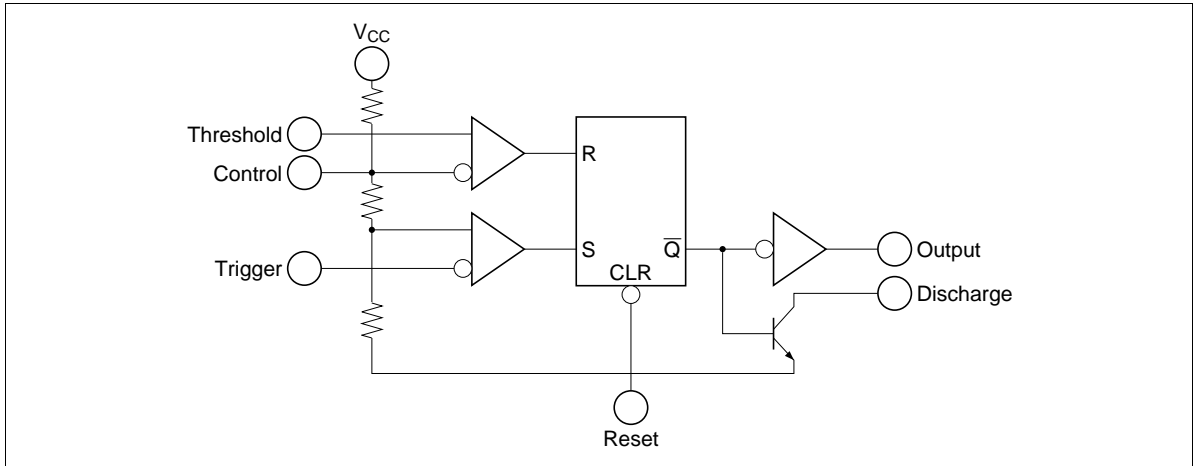

HA17555 Series

Absolute Maximum Ratings (Ta = 25°C)

Item	Symbol	HA17555PS/FP	HA17555/F	Unit
Supply voltage	V _{cc}	18	18	V
Discharge current	I _T	200	200	mA
Output source current	I _{source}	200	200	mA
Output sink current	I _{sink}	200	200	mA
Power dissipation*1	P _T	600/385	600/385	mW
Operating temperature	T _{opr}	-20 to +75	-20 to +70	°C
Storage temperature	T _{stg}	-55 to +125	-55 to +125	°C

Note: 1. For the HA17555/PS,

This value applies up to Ta = 50°C; at temperatures above this, 8.3mW/°C derating should be applied.

For the HA17555F/FP,

This value applies up to Ta = 25°C; at temperatures above this, 3.85mW/°C derating should be applied.

See notes on SOP Package Usage in Reliability section.

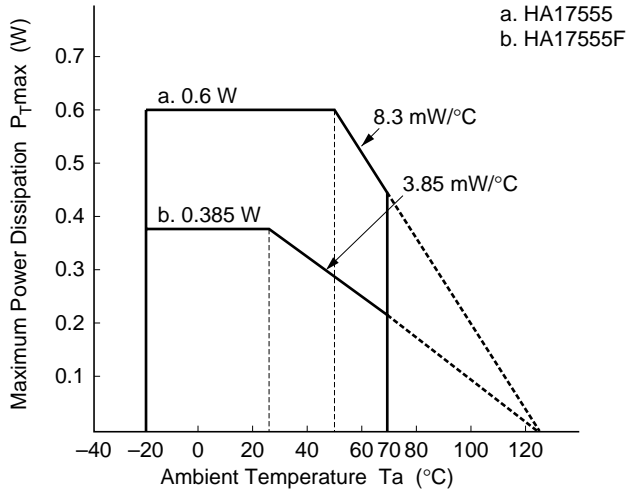
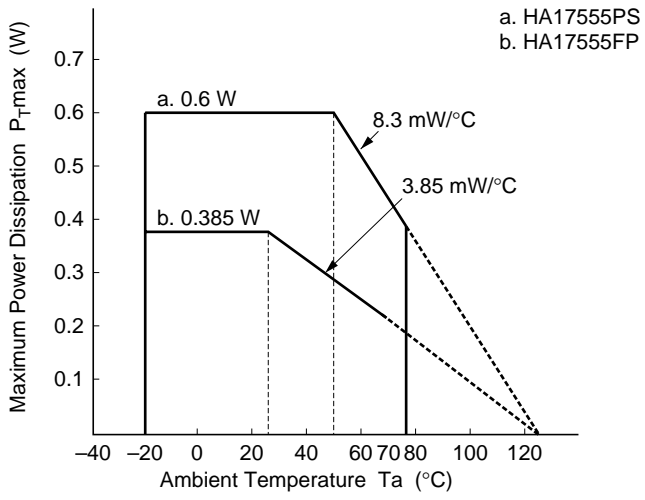

Electrical Characteristics ($V_{CC} = 5$ to 15 V, $T_a = 25^\circ\text{C}$)

Item	Symbol	Min	Typ	Max	Unit	Test conditions
Supply voltage* ¹	V_{CC}	4.5	—	16.0	V	
Supply current	I_{CC}	—	3.0	6.0	mA	$V_{CC} = 5$ V, $R_L = \infty$
	I_{CC}	—	10	15	mA	$V_{CC} = 15$ V, $R_L = \infty$
Timing error* ² (Inherent error)	E_t	—	1.0	—	%	
Timing error* ² (T_a dependency)	E_t	—	50	—	ppm/ $^\circ\text{C}$	$T_a = -20$ to $+75^\circ\text{C}$
Timing error* ² (Voltage dependency)	E_t	—	0.01	—	%/V	$V_{CC} = 5$ to 15 V
Threshold voltage	V_{th}	—	2/3	—	$V \times V_{CC}$	
Trigger voltage	V_T	—	5.0	—	V	$V_{CC} = 15$ V
	V_T	—	1.67	—	V	$V_{CC} = 5$ V
Trigger current	I_T	—	0.5	—	μA	
Reset voltage	V_R	0.2	0.5	1.0	V	
Reset current	I_R	—	0.1	—	mA	
Threshold current	I_{th}^{*3}	—	0.1	0.25	μA	
Control voltage	V_{CL}	9	10	11	V	$V_{CC} = 15$ V
	V_{CL}	2.6	3.33	4.0	V	$V_{CC} = 5$ V
Output voltage	V_{OL}	—	0.1	0.25	V	$V_{CC} = 15$ V, $I_{sink} = 10$ mA
		—	0.4	0.75	V	$V_{CC} = 15$ V, $I_{sink} = 50$ mA
		—	2.0	2.5	V	$V_{CC} = 15$ V, $I_{sink} = 100$ mA
		—	2.5	—	V	$V_{CC} = 15$ V, $I_{sink} = 200$ mA
		—	0.25	0.35	V	$V_{CC} = 5$ V, $I_{sink} = 5$ mA
Output voltage	V_{OH}	—	12.5	—	V	$V_{CC} = 15$ V, $I_{source} = 200$ mA
		12.75	13.3	—	V	$V_{CC} = 15$ V, $I_{source} = 100$ mA
		2.75	3.3	—	V	$V_{CC} = 5$ V, $I_{source} = 100$ mA
Output rise time	t_r	—	100	—	ns	No loading
Output fall time	t_f	—	100	—	ns	No loading
Oscillation pulse width* ⁴	tw	10.0	—	—	ns	

Notes: 1. When output is low (When it is high, I_{CC} is lower by 1 mA typically.)

2. $R_A, R_B = 1$ k to 100 k Ω , $C = 0.1$ μF , $V_{CC} = 5$ V or 15 V.

3. ($R_A + R_B$) at $V_{CC} = 15$ V is determined by the value of I_{th} . It is 20 M Ω Max.

4. Output pulse width at mono multi circuit. Output high level pulse width at astable circuit.

Characteristic Curves

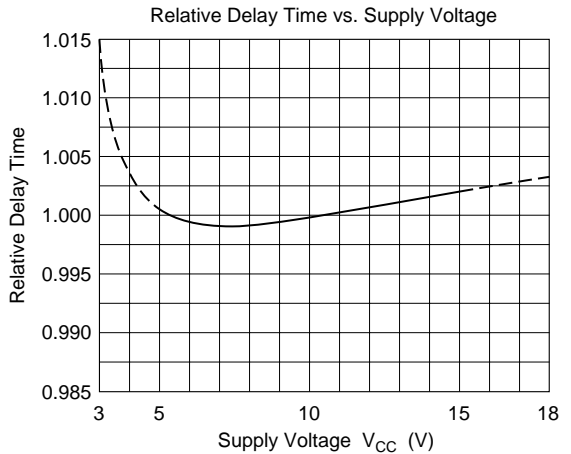
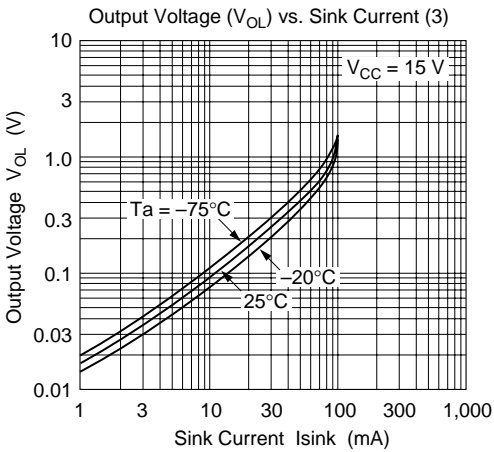
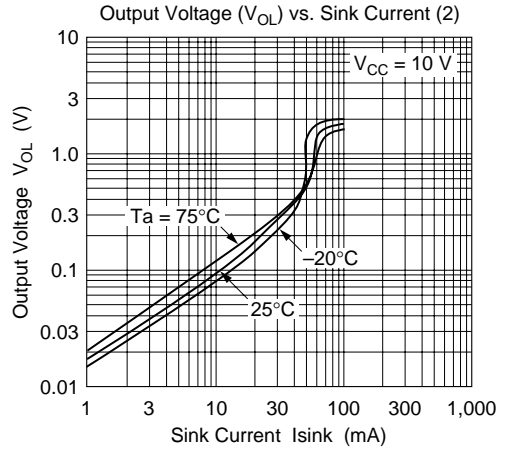
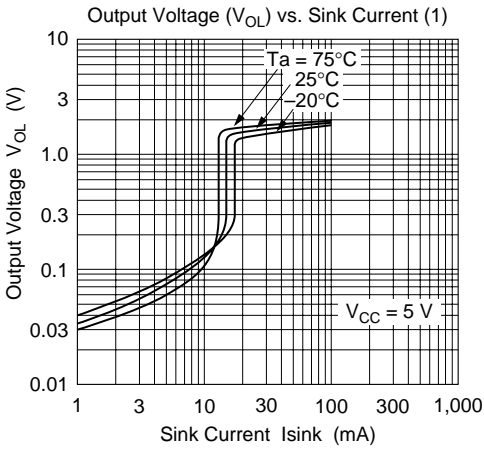
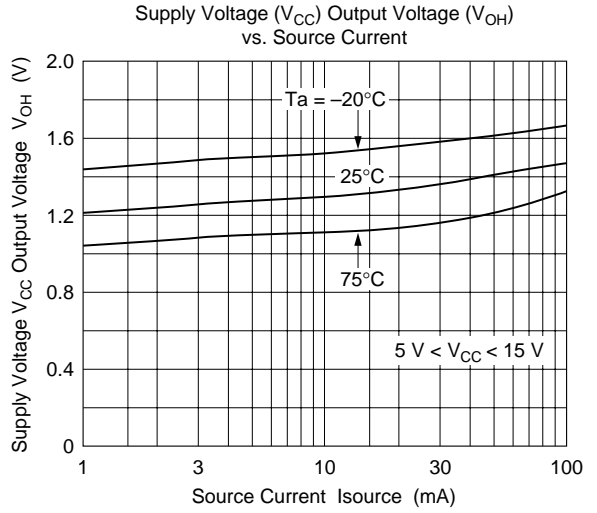
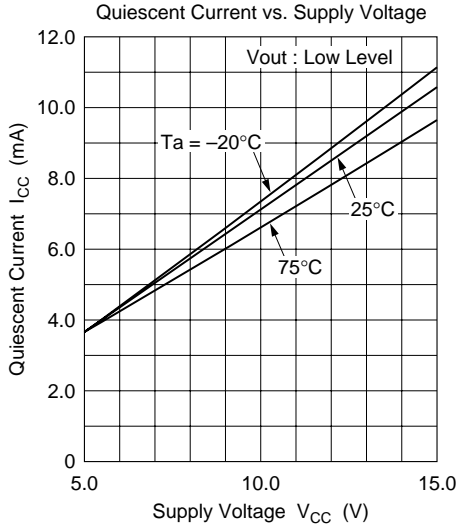

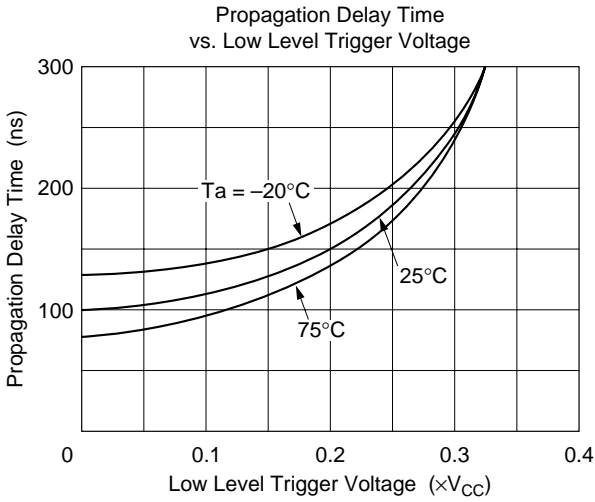
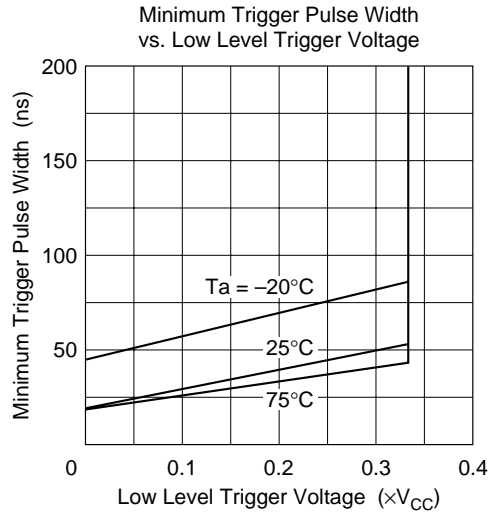
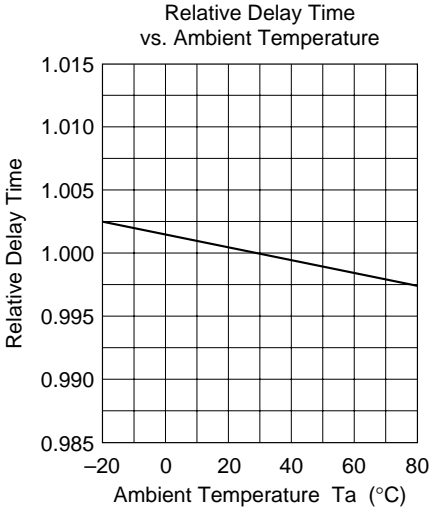

Package Dimensions

Unit: mm

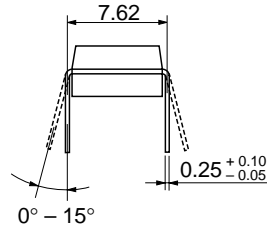
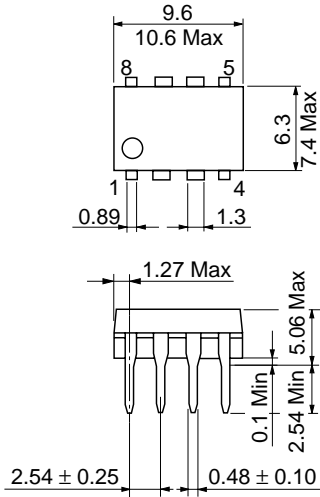

Hitachi Code	DP-8
JEDEC	Conforms
EIAJ	Conforms
Mass (reference value)	0.54 g

Unit: mm

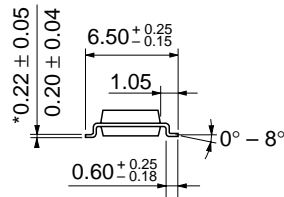
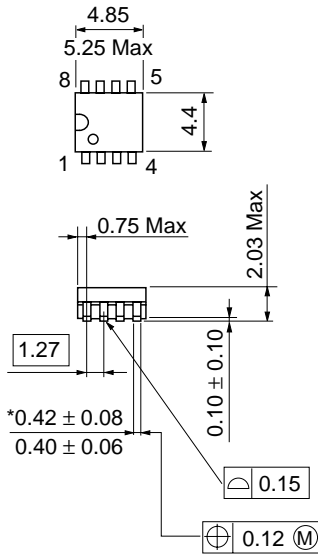

Hitachi Code	FP-8D
JEDEC	—
EIAJ	Conforms
Mass (reference value)	0.10 g

*Dimension including the plating thickness
Base material dimension

Cautions

1. Hitachi neither warrants nor grants licenses of any rights of Hitachi's or any third party's patent, copyright, trademark, or other intellectual property rights for information contained in this document. Hitachi bears no responsibility for problems that may arise with third party's rights, including intellectual property rights, in connection with use of the information contained in this document.
2. Products and product specifications may be subject to change without notice. Confirm that you have received the latest product standards or specifications before final design, purchase or use.
3. Hitachi makes every attempt to ensure that its products are of high quality and reliability. However, contact Hitachi's sales office before using the product in an application that demands especially high quality and reliability or where its failure or malfunction may directly threaten human life or cause risk of bodily injury, such as aerospace, aeronautics, nuclear power, combustion control, transportation, traffic, safety equipment or medical equipment for life support.
4. Design your application so that the product is used within the ranges guaranteed by Hitachi particularly for maximum rating, operating supply voltage range, heat radiation characteristics, installation conditions and other characteristics. Hitachi bears no responsibility for failure or damage when used beyond the guaranteed ranges. Even within the guaranteed ranges, consider normally foreseeable failure rates or failure modes in semiconductor devices and employ systemic measures such as fail-safes, so that the equipment incorporating Hitachi product does not cause bodily injury, fire or other consequential damage due to operation of the Hitachi product.
5. This product is not designed to be radiation resistant.
6. No one is permitted to reproduce or duplicate, in any form, the whole or part of this document without written approval from Hitachi.
7. Contact Hitachi's sales office for any questions regarding this document or Hitachi semiconductor products.

HITACHI

Hitachi, Ltd.

Semiconductor & Integrated Circuits.
Nippon Bldg., 2-6-2, Ohte-machi, Chiyoda-ku, Tokyo 100-0004, Japan
Tel: Tokyo (03) 3270-2111 Fax: (03) 3270-5109

URL NorthAmerica : <http://semiconductor.hitachi.com/>
 Europe : <http://www.hitachi-eu.com/hel/ecg>
 Asia : <http://sicapac.hitachi-asia.com>
 Japan : <http://www.hitachi.co.jp/Sicd/indx.htm>

For further information write to:

Hitachi Semiconductor
(America) Inc.
179 East Tasman Drive,
San Jose, CA 95134
Tel: <1> (408) 433-1990
Fax: <1> (408) 433-0223

Hitachi Europe GmbH
Electronic Components Group
Dornacher StraÙe 3
D-85622 Feldkirchen, Munich
Germany
Tel: <49> (89) 9 9180-0
Fax: <49> (89) 9 29 30 00

Hitachi Europe Ltd.
Electronic Components Group.
Whitebrook Park
Lower Cookham Road
Maidenhead
Berkshire SL6 8YA, United Kingdom
Tel: <44> (1628) 585000
Fax: <44> (1628) 585160

Hitachi Asia Ltd.
Hitachi Tower
16 Collyer Quay #20-00,
Singapore 049318
Tel: <65>-538-6533/538-8577
Fax : <65>-538-6933/538-3877
URL : <http://www.hitachi.com.sg>

Hitachi Asia Ltd.
(Taipei Branch Office)
4/F, No. 167, Tun Hwa North Road,
Hung-Kuo Building,
Taipei (105), Taiwan
Tel: <886>-(2)-2718-3666
Fax : <886>-(2)-2718-8180
Telex : 23222 HAS-TP
URL : <http://www.hitachi.com.tw>

Hitachi Asia (Hong Kong) Ltd.
Group III (Electronic Components)
7/F., North Tower,
World Finance Centre,
Harbour City, Canton Road
Tsim Sha Tsui, Kowloon,
Hong Kong
Tel : <852>-(2)-735-9218
Fax : <852>-(2)-730-0281
URL : <http://www.hitachi.com.hk>

Copyright © Hitachi, Ltd., 2000. All rights reserved. Printed in Japan.
Colophon 2.0

HITACHI