

DESCRIPTION

PT6302 is a dot matrix VFD Driver/Controller IC utilizing CMOS Technology specially designed to display characters, numerals, and symbols. PT6302 provides 35 dot matrix plus 2 additional segment drivers and 16 grid drivers. 248 types of character data (CGROM), 8 types of character data (CGRAM), 16 display digits x 2 bits symbol data, 16 display digits x 8 bits register for character data display and 2 general output bits for static operation are provided. Pin assignments and application circuit are optimized for easy PCB layout and cost saving advantages.

FEATURES

- CMOS Technology
- Logic Power Supply: $VDD = 3.3\text{ V} \pm 10\%$ or $5.0\text{ V} \pm 10\%$
- VFD Drive Power Supply: $VEE = -20\text{V to } -30\text{V}$
- Built-in Oscillation Circuit (External RC)
- One-Byte Instruction Execution (not including Data Write to RAM)
- Microcontroller Interface
- Display Contents:
 - Character Generator ROM (CGROM): 5x7 Dots (248 Character Data Types)
 - Character Generator RAM (CGRAM): 5x7 Dots (8 Character Data Types)
 - Additional Data RAM (ADRAM): 16 Display Digits x 2 Bits (Symbol Data)
 - Data Control RAM (DCRAM): 16 Display Digits x 8 Bits (Character Data Display Register)
 - General Output Port: 2 Bits (Static Operation)
- Display Control Function:
 - Display Digits : 9 to 16 Digits
 - Display Duty (Contrast Adjustment) : 8 stages
 - All Display Lights : ON/OFF Mode

APPLICATIONS

- Microcontroller Peripheral Device
- Audio/Video Equipment

INPUT & OUTPUT CONFIGURATION

- Logic Input Pins

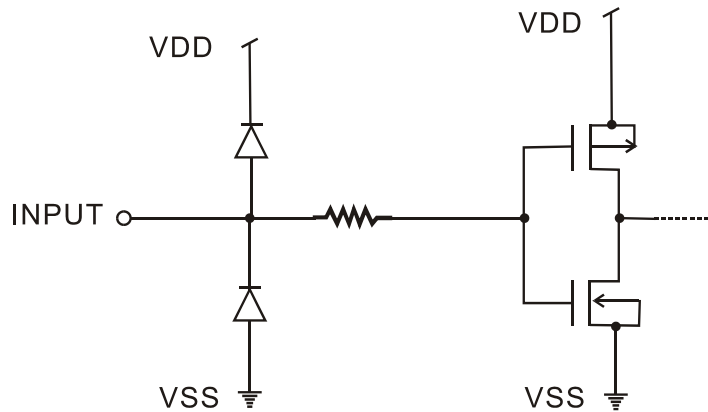

- Logic Output Pins

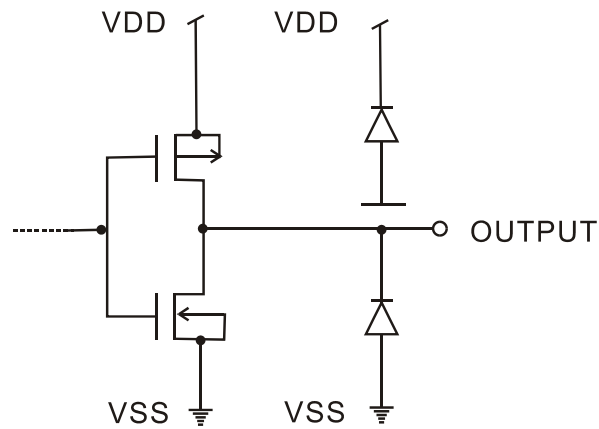

- Driver Output Pins

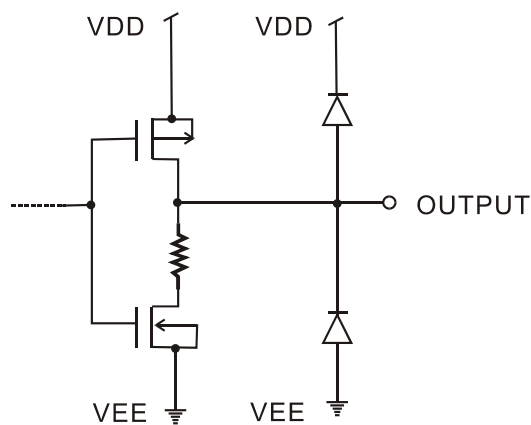

APPLICATION CIRCUIT

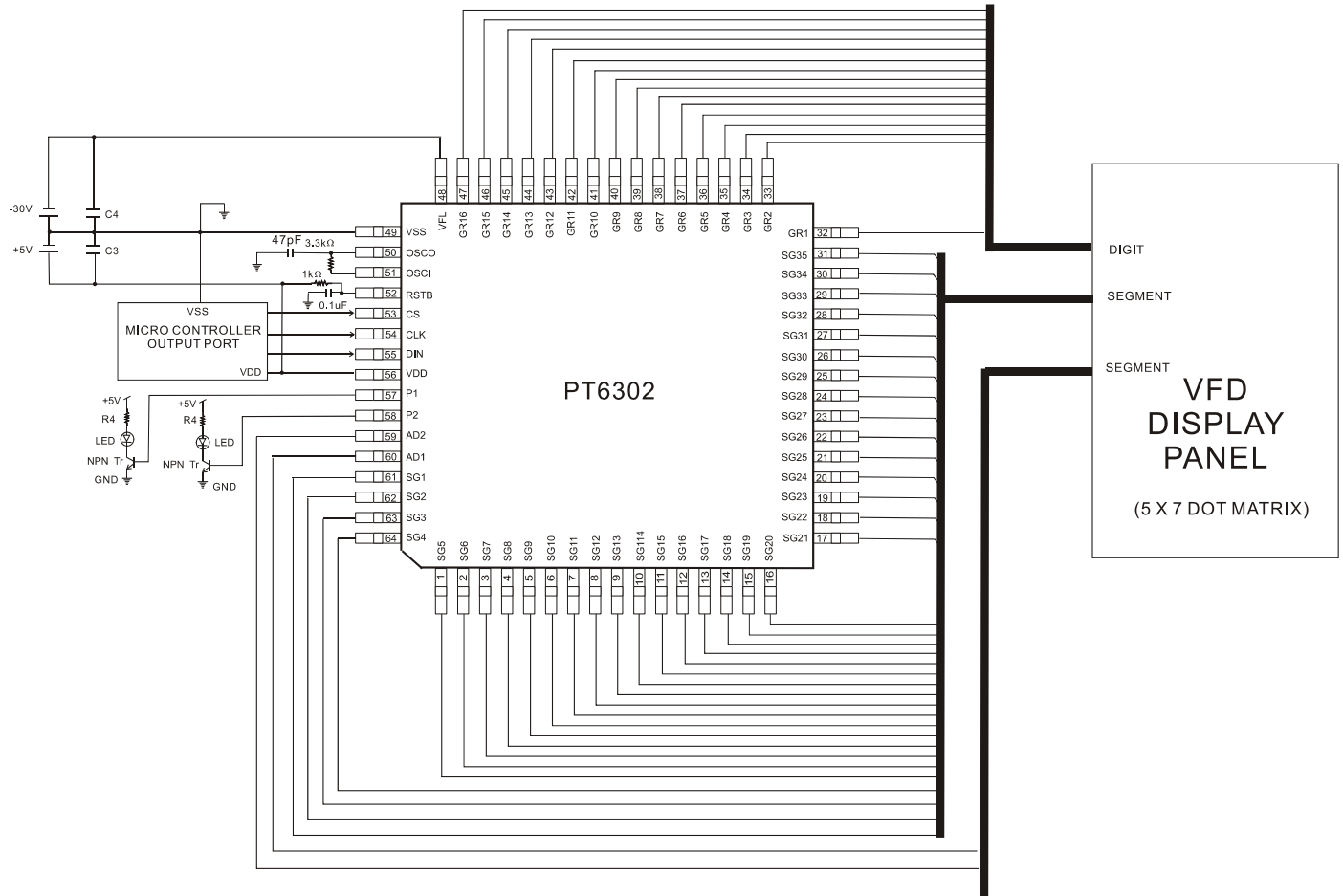

ORDERING INFORMATION

Order Part Number	Package Type	Top Code
PT6302LQ-001	64-pin LQFP	PT6302LQ-001
PT6302-R-001	64-pin SSOP	PT6302-R-001
PT6302LQ-002	64-pin LQFP	PT6302LQ-002
PT6302-R-002	64-pin SSOP	PT6302-R-002
PT6302-R-003	64-pin, SSOP	PT6302-R-003
PT6302LQ-003	64-pin, LQFP	PT6302LQ-003
PT6302-003-H	CIG	-
PT6302-R-004	64-pin, SSOP	PT6302-R-004
PT6302LQ-004	64-pin, LQFP	PT6302LQ-004
PT6302-R-005	64-pin, SSOP	PT6302-R-005
PT6302LQ-005	64-pin, LQFP	PT6302LQ-005
PT6302-R-006	64-pin, SSOP	PT6302-R-006
PT6302LQ-006	64-pin, LQFP	PT6302LQ-006
PT6302-007-H	CIG	-
PT6302LQ-001 (L)	64-pin LQFP	PT6302LQ-001
PT6302-R-001(L)	64-pin SSOP	PT6302-R-001
PT6302LQ-002 (L)	64-pin LQFP	PT6302LQ-002
PT6302-R-002 (L)	64-pin SSOP	PT6302-R-002
PT6302-R-003 (L)	64-pin, SSOP	PT6302-R-003
PT6302LQ-003 (L)	64-pin, LQFP	PT6302LQ-003
PT6302-R-004 (L)	64-pin, SSOP	PT6302-R-004
PT6302LQ-004 (L)	64-pin, LQFP	PT6302LQ-004
PT6302-R-005 (L)	64-pin, SSOP	PT6302-R-005
PT6302LQ-005 (L)	64-pin, LQFP	PT6302LQ-005
PT6302-R-006 (L)	64-pin, SSOP	PT6302-R-006
PT6302LQ-006 (L)	64-pin, LQFP	PT6302LQ-006

Notes:

1. (L) = Lead Free
2. The Lead Free mark is put in front of the date code.